

FILSER ELECTRONIC GMBH
16.04.2002

DX 50 FAI
DX 50
GPS-Fly information centre
User guide

Introduction

The DX-50 represents a GPS-Variometer system of the latest generation. The instrument is the combination of modern GPS technology and traditional Variometer system.

This manual will lead you to understand the device, its functions and all the advantages. Please read it carefully before you build in the device. The best way to learn the basic and more advanced features about the DX-50 is to turn it on at home and go through this manual step by step. We have tried our best to reduce in flight handling. , This is dependent on optimal on-ground preparation.

Please beware that the airfield data (frequency, altitude, etc.) can very easily change (lose their topicality).

Therefore the appropriate on-ground preparation and the use of appropriate data is indispensable.

The manufacturer doesn't take the responsibility for any possible mistakes or misprints in this text and gives no guaranty for accuracy of this manual. Any possible technical alterations of the device itself or software are naturally excluded.

This manual has been written with all attention and we have made our best to avoid any mistakes but with all respect please check any doubtful statement and let us know. We would be very grateful and for any comment we thank you in advance.

Our address:

FILSER ELECTRONIC GmbH
Gewerbestraße 2
D-86875 Waal
Tel.: +49 (0)8246/9699-0
Fax.: +49 (0)8246/1049

CONTENTS

1	GENERAL DESCRIPTION	1
1.1	Technical data	1
1.2	Variometer system	1
1.3	Electronic altitude meter	2
1.4	GPS-Navigation.....	2
1.5	Flight computer.....	3
1.6	Flight path recording.....	3
1.7	Airport and turning point database	3
1.8	Coordinates	3
1.9	Glider polars	4
2	INSTALLATION	5
2.1	Mechanical fixing.....	5
2.2	Antenna.....	5
2.3	Pneumatic connection.....	5
2.4	Wiring.....	6
3	OPERATION	8
3.1	Control elements	8
3.2	Data editing and selction	9
3.2.1	The wing load adjustment	10
3.2.2	Input of the McCready values	10
4	DISPLAY PRESENTATION	11
4.1	Glider navigation display 1	11
4.2	Graphic display.....	12

4.3	Arrival display	13
4.4	Info-Display	15
4.4	Info-Display	15
5.1	Airport (APT) program.....	17
5.1	Airport (APT) program.....	17
5.1.1	TEAM.....	18
5.1.2	WIND.....	18
5.2	Turning point (TP) program.....	20
5.2	Turning point (TP) program.....	20
5.2.1	Quick TP	21
5.3	Task (TSK) program	22
5.3.1	<i>Selection of a TASK.....</i>	23
5.3.2	Change of a TASK (TSK EDIT).....	23
5.3.3	<i>Programming of a new TASK.....</i>	24
5.3.4	<i>Deletion of a TASK (DELETE)</i>	26
5.3.5	<i>Flying with a TASK</i>	27
5.3.5	<i>Flying with a TASK</i>	27
5.3.6	Starting of a TASK.....	27
5.3.7	Restart of a TASK (TSK Restart).....	28
5.3.8	QNH RES.....	31
5.3.9	LOGGER (only by DX50 FAI).....	31
5.3.10	INIT.....	32
5.3.11	DISPLAY (graphic display).....	32
5.3.12	PC.....	32
5.3.13	PASSWORD	32
5.3.14	TSK.....	32
5.3.15	GPS	33
5.3.16	UNITS.....	33
5.3.17	SYMBOL	33
5.3.18	AIRSPACE	33
5.3.19	NMEA.....	33
5.3.20	PC (Adjustments).....	34
5.3.21	TE COMP.	35
5.3.21	TE COMP.	35
5.3.22	AUDIO.....	36
5.3.22	AUDIO.....	36

5.3.23 INPUT..... 36

5.3.24 INDICATOR..... 36

5.4 Near Airport program..... 37

5.5 Statistic program 38

5.6 POS program 41

6 APPENDIX 43

..... 43

6.1 Cable connection 43

6.2 Drilling plan 44

6.3 Short notes..... 44

1 General description

1.1 Technical data

Voltage supply:	9 - 30 VDC
Current input (volume 0):	ca. 300 mA at 12V
Operating temperature:	-20 to +60 °C
Storage temperature:	-30 to +80 °C
Dimensions:	96x190 mm
Total weight:	ca. grams
GPS receiver:	8-Chanel, parallel
Pressure probe:	1 silicium pressure probe for altimeter (vario) and flight

1.1.1 The difference between the DX 50 FAI and DX 50

The DX 50 FAI is an official FAI logger which is accepted by the IGC (International gliding commission). All the in-flight functions are the same by both instruments; the only difference is that the DX 50 has no logger menu and all its functions. Therefore the record flights or DMST flights can't be documented when you are flying with DX 50.

1.2 Variometer system

The variometer system consists of these functions:

- Total energy compensating variometer (TEC variometer)
- Netto relative variometer
- Interval integrator
- Speed command
- Tone generator

The interval integrator calculates the average climbing rate with the time constant, which can be defined by user.

For the speed command calculation the polars are available for some of the more common glider types. For calculation of some other parameters the included PC program "POLAR.EXE" is available. The DX 50 enables you to put in these values.

The speed command signal is optically marked as SC on the main display and as an arrow on the LCD indicator (vario is marked with a circle on the same place). There is a special audio signal during the speed command (no beeb in + and there is a dead area of audio around zero). The dead audio area can be adjusted in DX 50 SETUP program.

The following changeable parameters influence on the speed command signal:

- the McCready value
- the wing loading
- the glider polar
- the wind
- muddy wings (degradation of the polar in % of the best glide ratio, BUGS in SETUP)

The units for wing loading can be selected (kg/m² or lb/ft²). It is also possible to enter the wing loading as the percentage multiplier (overload) of the standard calculated wing load. The wing load value can be changed in 10% steps to maximum of 60% (= 1.6).

The BUGS value can be altered in 2,5%- steps to max. 30%, of the best glide ratio. This causes the deterioration of the glider polar.

There are several different filters available in the SETUP program for the variometer. The lower the filter value entered, the lower the speed command dead area.

- the smallest filter for calm air
- the biggest filter for turbulent air

1.3 Electronic altitude meter

The electronic altitude meter in DX 50 operates with the newest temperature compensated pressure probe. All the altitudes shown in DX 50 are barometric altitudes and not GPS altitudes.

After you have turned on the DX 50 you will be asked to enter the current local altitude. The blinking altitude is the altitude of the last landing point from the database. After the altitude entry the current QNH should be entered. This pressure is shown on the barometric altitude meter after the local altitude entry in the hp- bzw. mb- window. The QNH entry is not necessary, but in DX 50 it is needed as a reference for the altitude meter, for during the flight the air pressure alterations could be entered.

During the flight the altitude meter alteration isn't possible without the previous QNH entry.

1.4 GPS-Navigation

By means of the integrated GPS navigation system the DX 50 is able to accurately calculate all position data. All courses respectively speeds calculated by the GPS are related to ground, that means that the indicated ground speed can deviate from the indicated airspeed. The largest deviations are caused by the altitude error of the airspeed indicator respectively by an existing wind component.

The following parameters are calculated by the GPS:

- Track (TRK)
- Bearing to the way point (BRG)
- Groundspeed (GS)
- Distance to the way point (DIS)

-
- Estimated time of arrival at the way point (ETA)
 - Estimated enroute time to the way point (ETE)
 - Selected course to the way point (DTK, desired track)

1.5 Flight computer

The flight computer in DX 50 calculates the glider's course deviation drawn on the actual distance from the next way point under consideration of the security altitude entered in the SETUP program. On the display the digital value of the quantitative glider's course deviation is indicated (for instance - 320m).

For wind calculation (direction and speed) five different options are available, which can be selected in all navigational programs.

The wind component, which is necessary for the flight is automatically calculated and considered.

For the flights it is possible to enter the last turn point also as check point. In this case the glider's course isn't calculated to the next turn point, but over the check point to the finish line. This is necessary when the last turn point is very close to the finish line, and so the final glide altitude can be reached before the last TP.

When the glider departs from the finish line, the necessary altitude for the safe return is calculated considering the actual wind component and entered safety altitude.

When the GPS during the flight for 60 seconds or longer receives no signal, turns the computer automatically traditional distance calculation on. The last from GPS calculated distance to selected way point is then used as the starting point.

1.6 Flight path recording

The flight path recorder in the DX 50 automatically records all position data of the airplane (position, altitude, vario). The recording is repeated every 20 seconds by the DX 50, by the DX 50 FAI the recordings are repeated accordingly to the preset interval in the LOGGER setup. The data can be read out by a PC or notebook, stored or printed.

1.7 Airport and turning point database

The DX 50 is able to store up to 5000 airports, 600 turning points and 100 tasks with 10 turning points each. In the original version already several thousands airports (in Europe) are stored. These easily can be selected by the user and can be modified or deleted. This can be done either directly at the DX 50 or leisurely at home if a PC is available.

A disc with the transfer and editing software is included with the DX 50

Please beware that the manufacturer can not guaranty for the accuracy of the airport and TP data after the date of their publishing.

1.8 Coordinates

The DX 50 enables you to enter the coordinates in degrees, minutes and seconds or decimal minutes. The favoured format can be selected in SETUP program.

Latitude (LAT): N/S GG.MM.mm or GG.MM.SS (N= North, S= South)
Longitude (LON): W/E GGG.MM.mm or GGG.MM.SS (W= West, E=East)
GG= degree
MM= minutes
mm= decimal minutes
SS = seconds

With the following formula seconds can be converted into decimal minutes:

$$\text{decimal minutes} = \frac{\text{seconds}}{0,6}$$

Before entering coordinates from already existing list please take note in which format these coordinates are given. The right coordinate format should be selected in SETUP program before the entry. If necessary the coordinates can be converted with the above-mentioned formula.

1.9 Glider polars

Nowadays in the DX 50 some 30 glider polars are stored which can be selected in SETUP menu. For the gliders, which polar are not included in this list, it is possible to define your own two polars that can be added to the existing list.

These polars are defined by 3 coefficients (a, b and c). These coefficients can be calculated by the program POLAR.EXE that is included on the software support disc. Three pairs of values need to be selected out of the speed polar diagram of the glider and entered in the program mentioned above. The coefficients a, b and c can then be entered in the DX 50. According to our experience the values by these airspeeds should be used: 100, 130 and 160 km/h.

2 Installation

Please read the following installation instructions carefully through before mounting the device into the glider.

2.1 Mechanical fixing

For the DX 50 a new fixing method of the instrument in the instrument panel has been developed.

The whole instrument can be removed very simply from the front side of the instrument panel. There are special pneumatical connectors that allow the removal of the instrument without disconnecting the plastic tubes. The same holds true for the electrical wiring. That means that the pilot needs only a few seconds to remove the instrument and brings it to the scoring office.

- prepare the instrument recess according to the drilling plan
- fix from behind the instrument holder
- mount the tubes on the Ptot, Pst and TE
- plug in the antenna

2.2 Antenna

The delivered GPS antenna has to be mounted in the airplane in such a way that the optical range to the sky is not obstructed. The cover of the instrument panel in the airplane is the best mounting position. It is also possible to Monte it underneath the instrument cover provided it is not made of carbon fiber reinforced plastics or metal (e.g. aluminium). Please pay attention that metallic parts or solar panels do not shield the antenna and that it is not mounted in the immediate vicinity of the magnetic compass.

It is recommended to test the receipt of the GPS signal with a provisionally mounted antenna first before mounting the antenna permanently. The antenna should only be mounted after an optimal mounting position has been found.

You can lay the antenna cable according to the following rules:

- the antenna cable should not be kinked
- it should be laid in as large a radius as possible
- do not wind up extra antenna cable to a ball or wind it round the antenna
- the antenna cable should never be laid close to other current-carrying leads or antenna cables

The delivered antenna should not be mounted outside the airplane. An antenna for outdoor installation is obtainable as accessory from Filser Electronic.

2.3 Pneumatic connection

On the back of the mounting frame there are three pneumatical connectors (static Pst, Pst TE, Total pressure Ptot). Pst is always connected to the static source of the glider using TE probe for compensation connect Pst TE to the TE probe. Ptot is always connected to the total pressure source of the glider (Pitot). See Figure 1 for details.

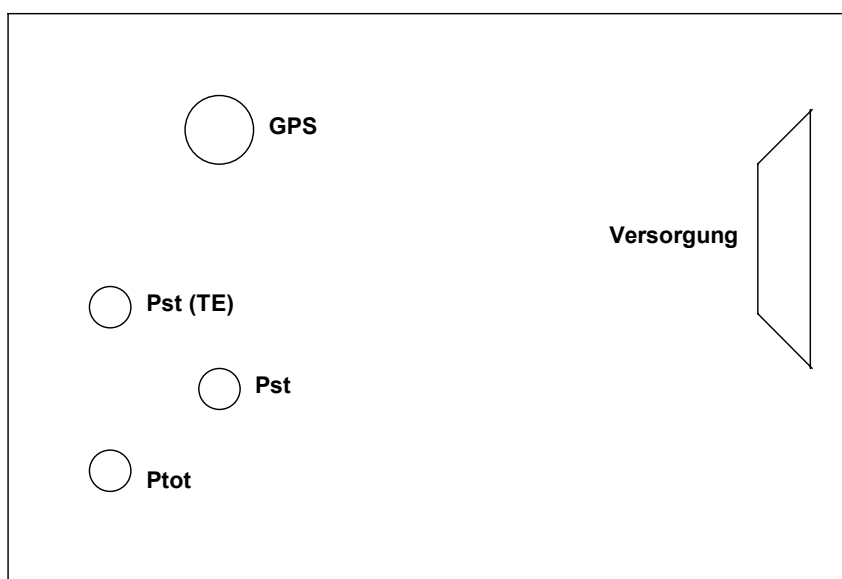

Figure 1: pneumatic connection

Attention:

Do not blow into the pressure connectors of the instrument, because the pressure sensors could be damaged.

2.4 Wiring

All the cables needed for the normal operating of the instrument are included in the package:

- All the cables are shielded

The two striped cable ends of the power supply cable have to be connected to the power supply in the glider. If possible use a supply cable with a large cross section and pay attention to a proper grounding.

The power supply (RED) should be protected with a fuse (1,0 Amp) in any case!!
 red end = PLUS
 blue end = MINUS/ground

The panel jack of the PC interface can be mounted in the instrument panel. If required the delivered interface cable to the PC COM port can then be plugged in the panel jack.

The speaker should be connected with the cinch jack to the cable set. The speaker should be as far from the magnetic compass as possible because of the possible disturbances of the compass.

The cable labeled SC is used for manual external speed command change over (switch on the stick or flaps).

The cable labeled NMEA will only be used when the external Moving-Map-System is run on the DX 50.

The accurate wiring plan is shown on the beginning of this manual.

3 Operation

The operation of the DX 50 was designed as user friendly and as simple as possible. Flying with the DX 50 is possible without a long familiarization.

3.1 Control elements

The control panel of the DX 50 is equipped with 14 key keyboard.

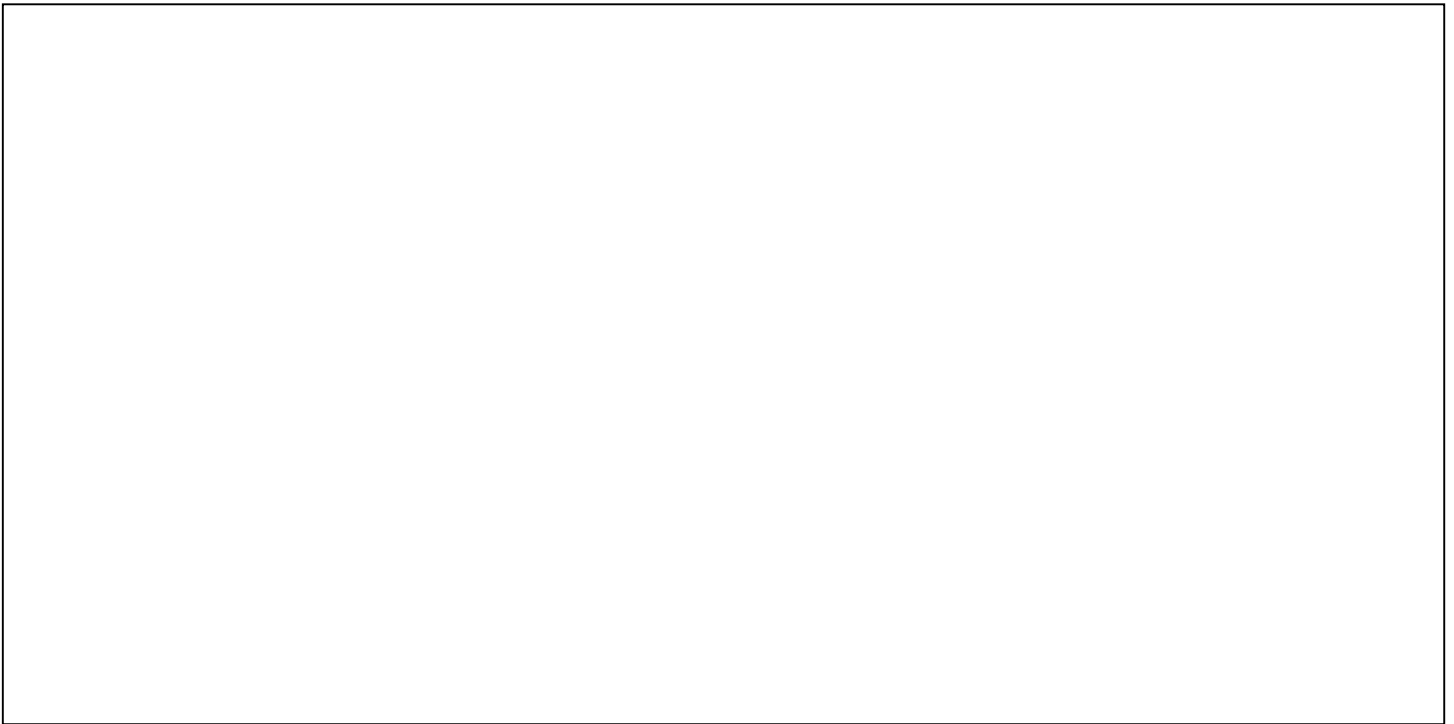

The control elements have the following functions:

	Function:
ON switch	used to switch the instrument ON
Mode selector	the device has 7 different modes, which can be easily selected with +/- keys
Up and down cursor keys	with this keys you can select the input data (e.g. to scan up and down the alphabet or the figures from 0 to 9)
Speaker	with the combination of this key and the +/- keys you can alter the speaker's volume
McCready switch	use MC key in combination with +/- keys to alter the McCready function
Ballast switch	use BAL and +/- keys to alter the ballast entry
ENTER button	With the ENTER-button the entered data are confirmed or activated and the menus are opened...
ESC button OFF	with the ESC button you can skip input data or return from already selected functions; if held for a longer time (few seconds) the instrument will turn OFF
START button	To start the programmed tasks (only possible when flying), to store the current position as way point (only in TP mode) and to operate the stopwatch (only in POS mode), as well as to return to the corresponding mode during the editing process. If you push the START button in the APT navigation program the full APT name will be displayed in the upper line.

After any button is pushed a short beep is heard!

3.2 Data editing and selection

Editing as well as selecting of data are done the same way in all modes of the DX 50. To reach a high degree of comfort a simple and especially logical operation of the instrument is used to guarantee a quick familiarization and an unmistakable operation.

When the instrument is ready for the input of a letter combination, e.g. a TP name the cursor flashes on the first position of the input field. Now you can select the different letters of the alphabet or figures from 0 to 9 by pushing the up and down cursor keys. If you push the ENTER button the selected letter or figure is stored and the cursor moves to the next position of the input field.

Using the START button the cursor can be moved one position to the left again to correct possible mistakes.

By pushing the ESC button the whole following data block can be skipped. This could be necessary e.g. if you do not want to push the ENTER button 4 times to store already indicated signs.

Example: the input of the airfield altitude

After the turning ON the DX 50 the current airfield altitude should be entered.

The different figures are then selected by up and down cursor keys; do not forget to confirm every chosen value by pushing ENTER. If the altitude displayed is correct, so you don't want to change it, then just push ESC to skip the whole figure block or confirm every figure by pushing the ENTER button.

Again, here is a short summary:

- to confirm an input ⇒ ENTER button
- to skip an input ⇒ ESC button
- to move the cursor to the left: ⇒ START button

These procedure is the same for all the inputs made.

3.2.1 The wing load adjustment

The actual wing load can be entered in kg/m², lb/ft² or as an OVERLOAD in percentage (1.2 equals 20% overload). The wanted unit can be selected in the SETUP program.

Example: how to calculate the overload percentage:

The glider polar that should be entered in the DX 50 is based on the wing load of 35 kg/m². But the actual wing load is 42 kg/m². This calculation should be made:

$$\text{Overload} = \frac{\text{current wing load } 42\text{kg/m}^2}{\text{standard wing load } 35\text{kg/m}^2} = 1,2$$

By this example the value 1,2 (that is 20% increased wing load) should also be put in. Independently of the selected wing load units the entered value appears on display.

3.2.2 Input of the McCready values

The input of the McCready values is done by pushing the MC button and by pushing + or - key shortly after, the input value appears on display.

4 DISPLAY presentation

The following figures show the display of the DX 50 and the indicated data:

4.1 Glider navigation display 1

The navigation display is the most needed information source of the DX 50. All required information for a precise navigation to a certain point is shown on this display. All calculated data are related to the waypoint that is shown in the first line.

BRG indicates the bearing to the waypoint
 DIS indicates the distance of the glider to the selected waypoint
 GS indicates the ground speed of the glider
 TRK indicates the track of the glider

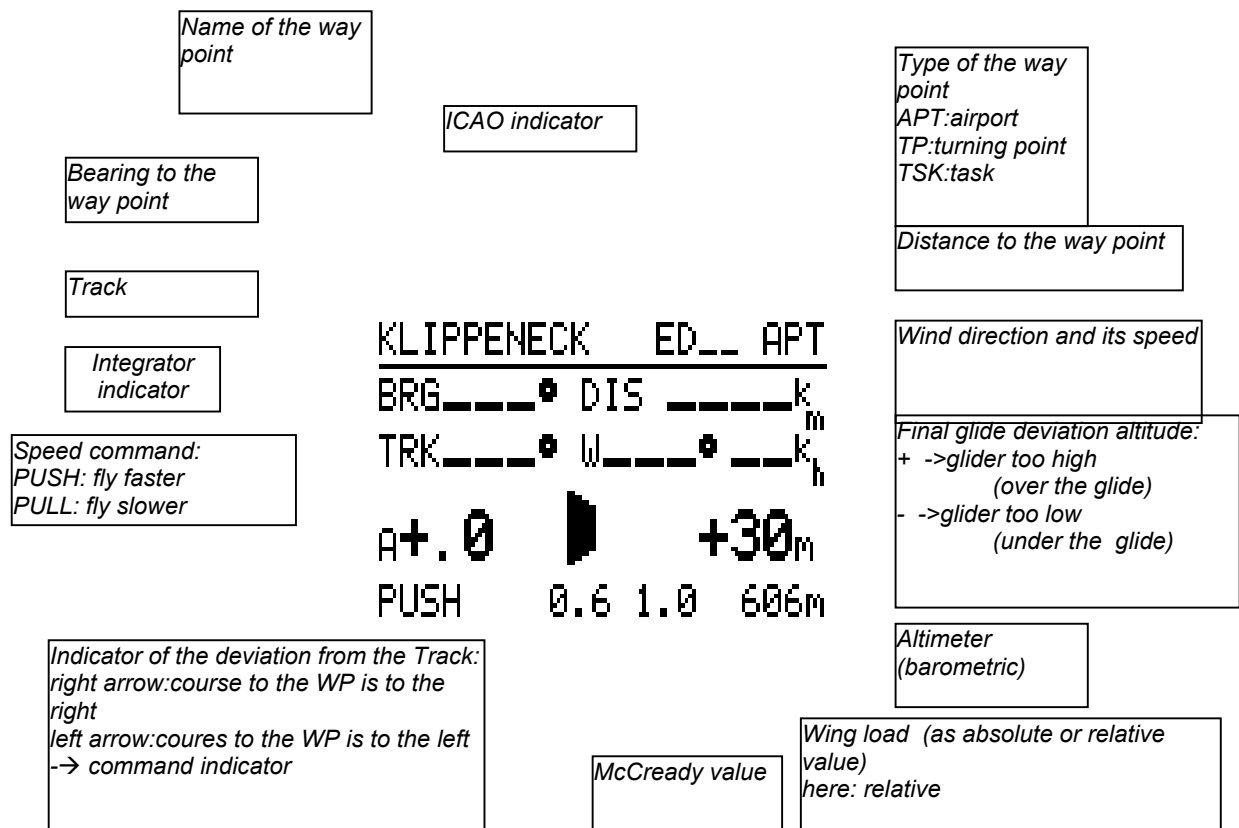

Figure 2: glider navigation display

4.2 Graphic display

The graphic display serves as a navigation support in a graphic and alphanumeric form in the APT, TP, and TSK modes.

The graphic display is second to the navigation display in the above mentioned modes. The graphic display is called by pushing the AB button.

The most important data as BRG (B), TRK (T), GS (G) and distance are shown on the right hand side of the display. The name of the selected waypoint appears in the shortened form.

In the graphic part of the display the current position of the glider is shown in relation to the selected course or to the selected waypoint respectively.

The different air space structures are shown all together or related to their type fading in or out (see SETUP).

Two different glider symbols are available and are configured in the SETUP program.

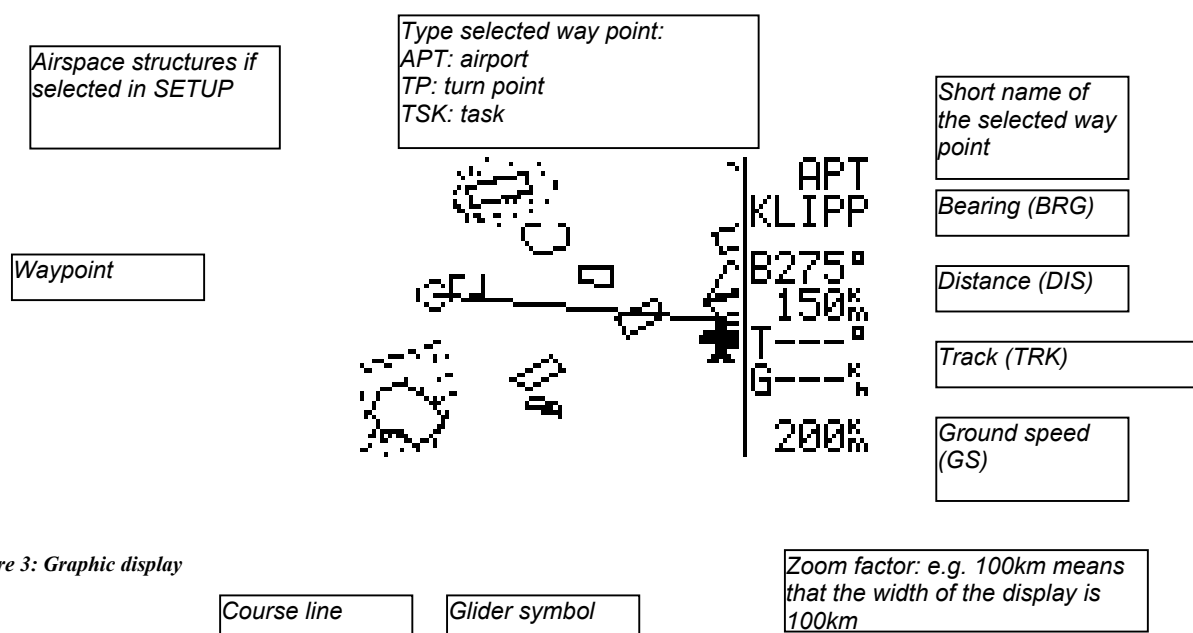

Figure 3: Graphic display

If there aren't enough satellites for the navigation in the lower part of the display the warning GPS BAD is displayed. **The ZOOM function** (“+” or “-” button) enables you to select the scale from 200 km to 100, 50, 20, 10, 5 and 2 km. The selected scale value is shown in the left bottom corner of the display. In the TASK mode ‘Z’ is displayed for ZOOM and the TSK, LEG or FS (photo sector) for the presented mode. By pushing the AB button the belonging navigation display is switched on.

4.5.3 Navigation display

All the required information for a precise navigation to a certain point is shown on the navigation display as well as on the glider navigation display described above. Some specific glider information is added to the bottom of a display as a scale that shows the lateral deviation from the selected course. The scale can be altered by pushing the + or - keys (only when the navigation display active is). The function can be compared with the OBS and CDI of a VOR receiver.

All calculated and displayed data are related to the waypoint or airfield that is shown in the first line.

- DTK This value can be selected by “+” or “-” button. It corresponds to the OBS of a VOR receiver. With a DTK a course can be selected. It is not adjustable in the TSK mode!!
- CDI indicates the lateral deviation from the selected course (DTK)
- XTE indicates the lateral deviation from the selected course (DTK) in km, nm or ml

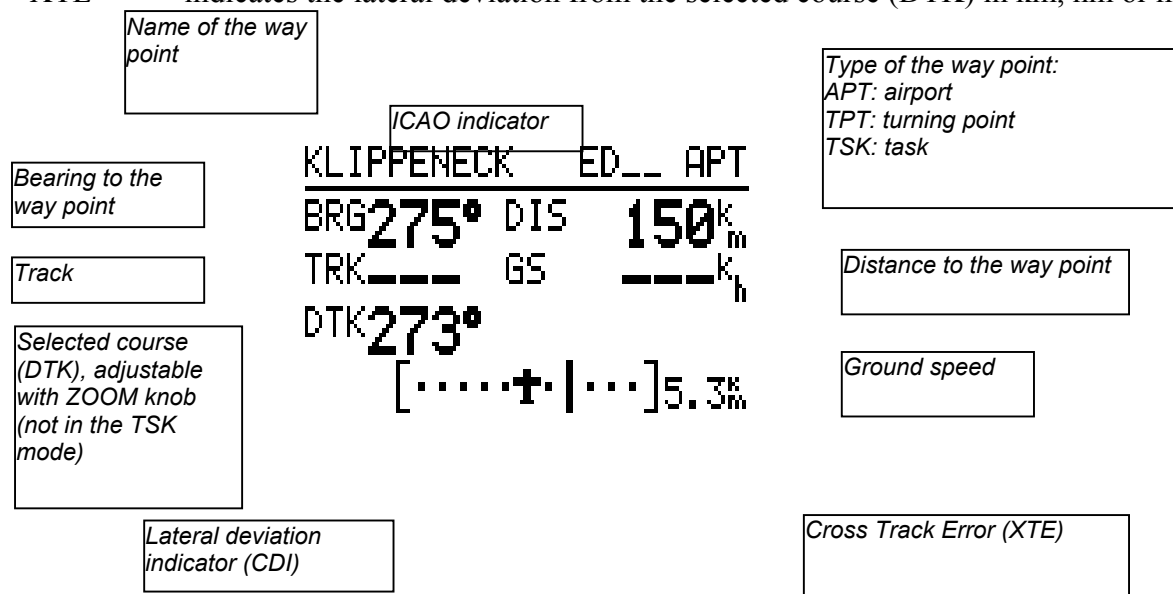

Figure 4: Navigation display

This display can be turned off in SETUP program with password (PAGE3) if not needed.

By pressing the AB button in the navigation menu the corresponding arrival display is shown.

4.3 Arrival display

The arrival display informs you about the arrival data of the currently approached waypoint in the APT, TP and TSK modes. The following data are displayed:

ACT.T	current time
ETA	estimated time of arrival
ETE	estimated time enroute
W	wind speed and direction
V	battery voltage
TC	Traffic Circuit altitude

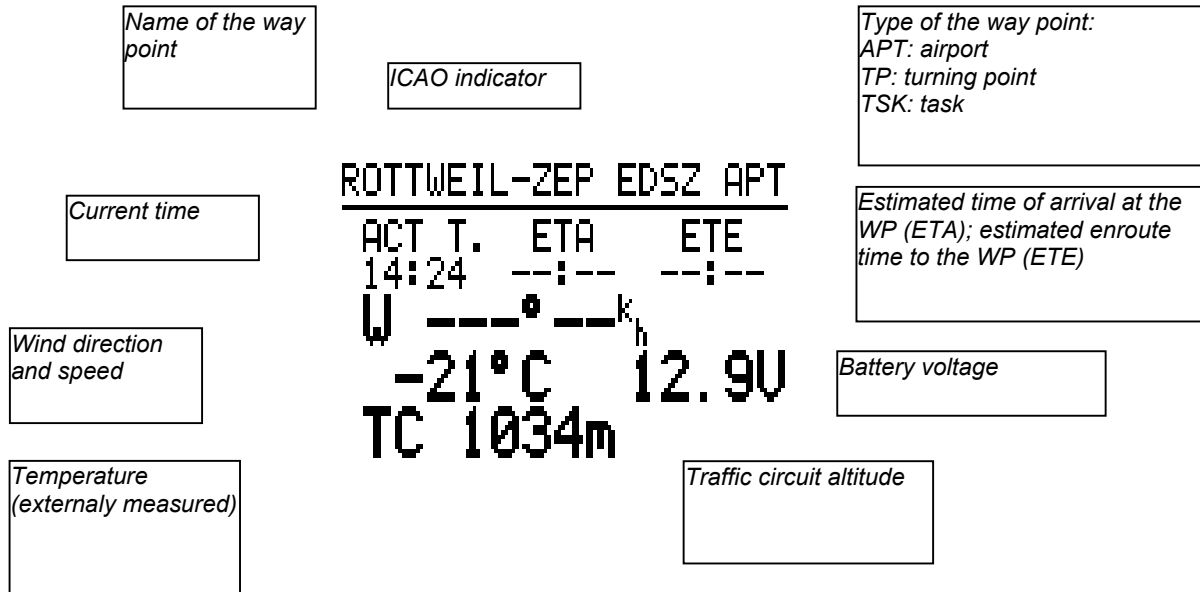

Figure 5: Arrival display

By pressing the AB button the INFO display is shown (holds true only if the airfield is selected as the next waypoint).

4.4 Info-Display

The INFO display shows all necessary data for the approach of an airport. If data for a certain airport are not published or if they are unknown minus signs (---) will be displayed at the corresponding positions.

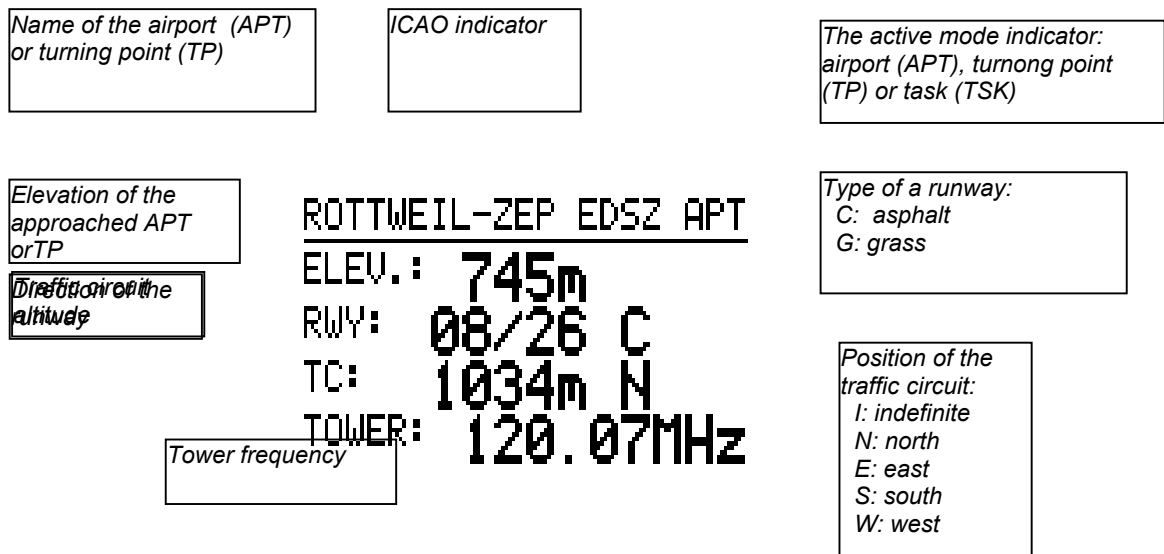

Figure 6: Info-Display

Attention:

The info display only appears if an airport (APT) is approached. If a turning point (TP) was programmed data such as tower frequency are not available.

5. Menu structure

The following figure shows the structure of the different program modes of the DX 50. The program modes can be selected by using the MODE button and short after the “ + ” or “ - ” key (regardless of which mode was selected before).

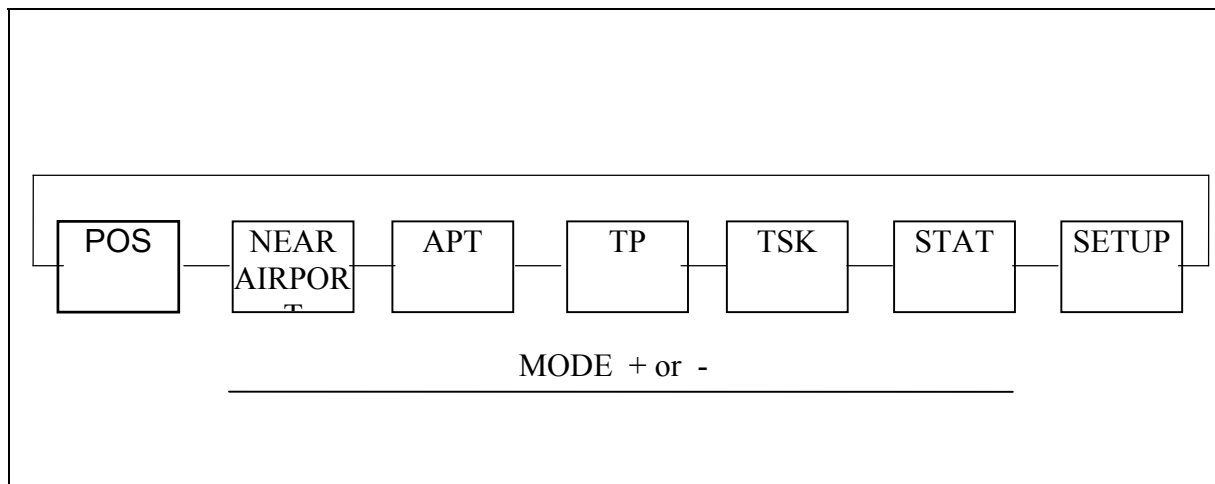

Figure 7: Structure of the program modes

The mode key stays active for a short time after it has been pushed, so you need to release the mode key and then press the + or - key to make the selection. It is also possible to skip some modes by pressing +/- keys repeatedly. The selected mode becomes active at once. There are seven different modes available:

POSITION	Indication of the current position (coordinates), current time, date and stopwatch.
NEAR APT	In this mode the distance and the course to the 10 closest airports is displayed.
APT	Used for the direct approach to the airport or to edit the airport database
TP	Used for the direct approach to the TP or to edit the TP database
TSK	Used to fly the previously programmed task as also to edit the task database
	In the APT, TP, and TSK modes the WIND calculations and TEAM function menus are available.
STATISTICS	The DX 50 offers you two different types of statistics: during the flight statistics and the statistics after the flight with the logbook.
SETUP	In setup program the system setup is made.

The APT and TP modes are almost identical. The difference is that in the APT mode all the data relate to the programmed airport but to the programmed turning point in the TP mode (which can also be an airport).

5.1 Airport (APT) program

In this mode all the functions related to the airports can be used: the navigation to the airport, mapping, airfield information as also the editing of the APT database (e.g. if the frequency of the airport has changed). In the APT mode the type of wind calculation can be determined and it also contains the TEAM function. The functions are also integrated in TP and TSK modes.

The following Figure 8 illustrates the program structure of the APT mode:

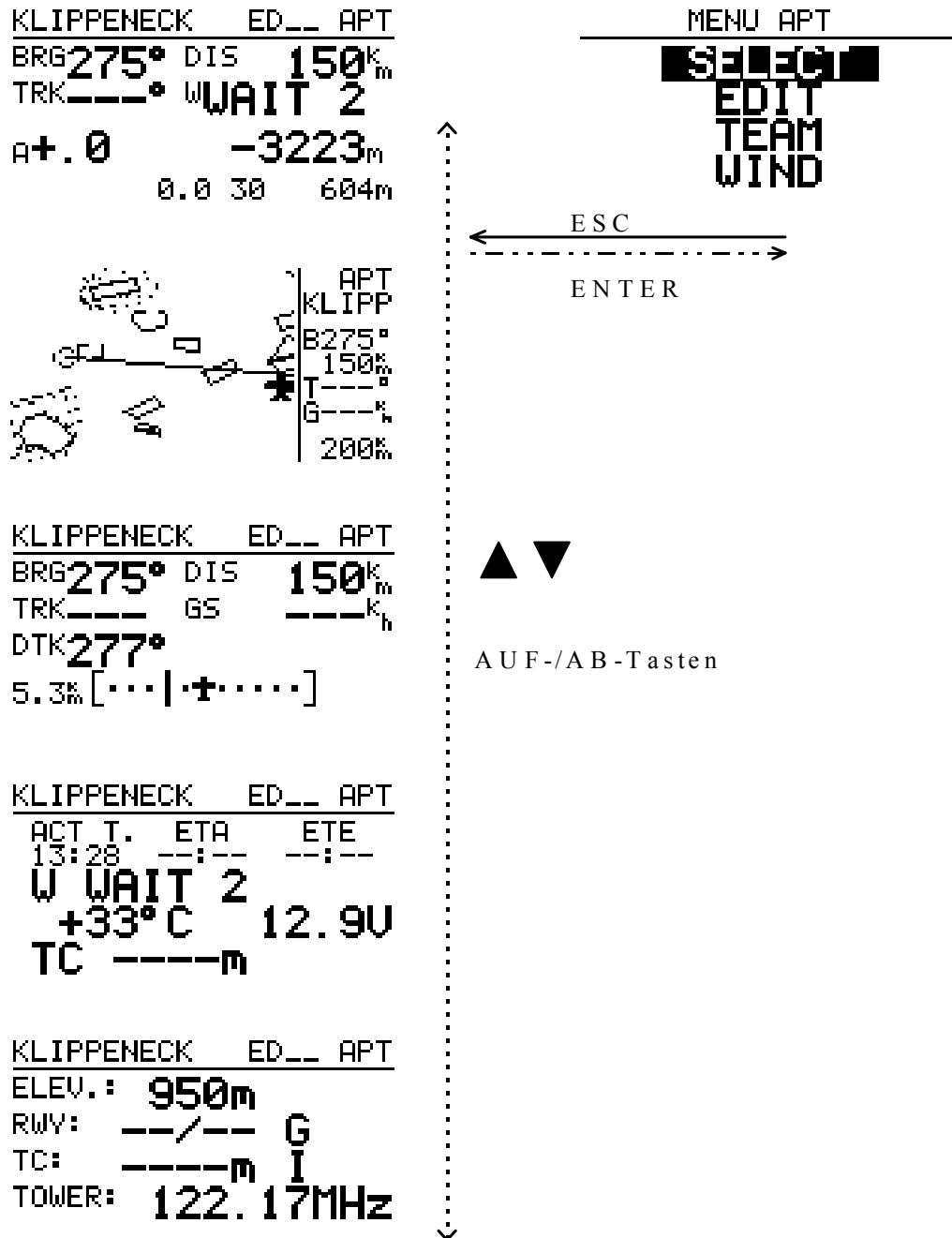

Figure 8: APT Mode structure

By pressing the “ENTER” key in the APT menu all the above shown submenus are available. The menus for selection and editing of the airports as well as the menus for the TEAM functions and wind calculation selection (WIND) are part of the APT mode. Use UP and DOWN arrows to select the above-mentioned menus and “ENTER” button to activate them.

Example: Selection of an APT:

After selecting the APT program with the MODE button the APT menu is activated by pressing the “ ENTER ” key. With the arrows keys the menu SELCT is selected and with ENTER key activated. Now there are two possibilities for search for the airfields:

a) Search for ICAO indicator	b) Search for name
Now enter the full ICAO indicator of the airport (every letter has to be confirmed by ENTER button).	Skip the input of the ICAO indicator by pushing the ESC button or pushing the ENTER button 4 times.
The DX 50 is searching the airport using the ICAO indicator and returns direct to the glider NAV display with the NAV data of the desired APT displayed.	Select the country of the desired airport by the UP/DOWN keys and push the ENTER button to confirm selection.
	Now you can enter the first four letters of the desired airport using the arrow key and ENTER key for confirmation.
	You will now find one or several airports in the bottom line of the display that start with the four entered letters. If more than one airport is indicated the desired one can be selected by the UP/DOWN keys and activated by pushing ENTER.
	The NAV data of the selected airfield are then displayed in the glider NAV menu.

5.1.1 TEAM

The TEAM menu enables group flights of two or more gliders; e.g. when you lose your partner out of sight or when you want to meet him on your way. With the TEAM menu you can follow your partners under condition that all the gliders are equipped with the GPS instruments (preferable with the DX 50) and are flying to the same waypoint.

Both partners have to select the same waypoint. The searched partner-B has to tell the partner-A his bearing and the distance to the selected waypoint by radio. These values are then entered by partner-A in the mode APT/menu TEAM of the DX 50. On the glider navigation display are then shown the navigation data directly to the partner-B.

5.1.2 WIND

The wind can be calculated (considered) in 4 different ways.

In the APT, TP or TSK menus the WIND menu can be selected. The following options are available:

FIX	manual input of a fixed value (speed and direction) (in SETUP program you are able to select different units for wind's speed) The resulted wind component will be considered by all the calculations made.
GS	Here the wind is determined over the glider's ground speed. This enables you to circle with the constant speed (IAS).
POS	Works only by climbing (minimum six turns to get the wind)
COMB.	Special algorithm where TAS, GS, TRK are taken in calculation and the result is the wind. The method is functioning during the climbing as well as by straight

flight where some track deviations are made.

The pilot has to choose the desired wind calculation. The pilot is able to change the method whenever he wants only one can be activated at the time.

Please take attention that the GS and POS methods can only be selected while circling and COMB only during the straight flight. If you select the FIX method your wind component is constant and isn't calculated.

5.2 Turning point (TP) program

In principle the TP function is identical to the APT mode. However the TP mode is only related to programmed TP's whereas the APT mode is only related to stored airports. Turning points are (TP) selected and edited in the same way as in the APT mode.

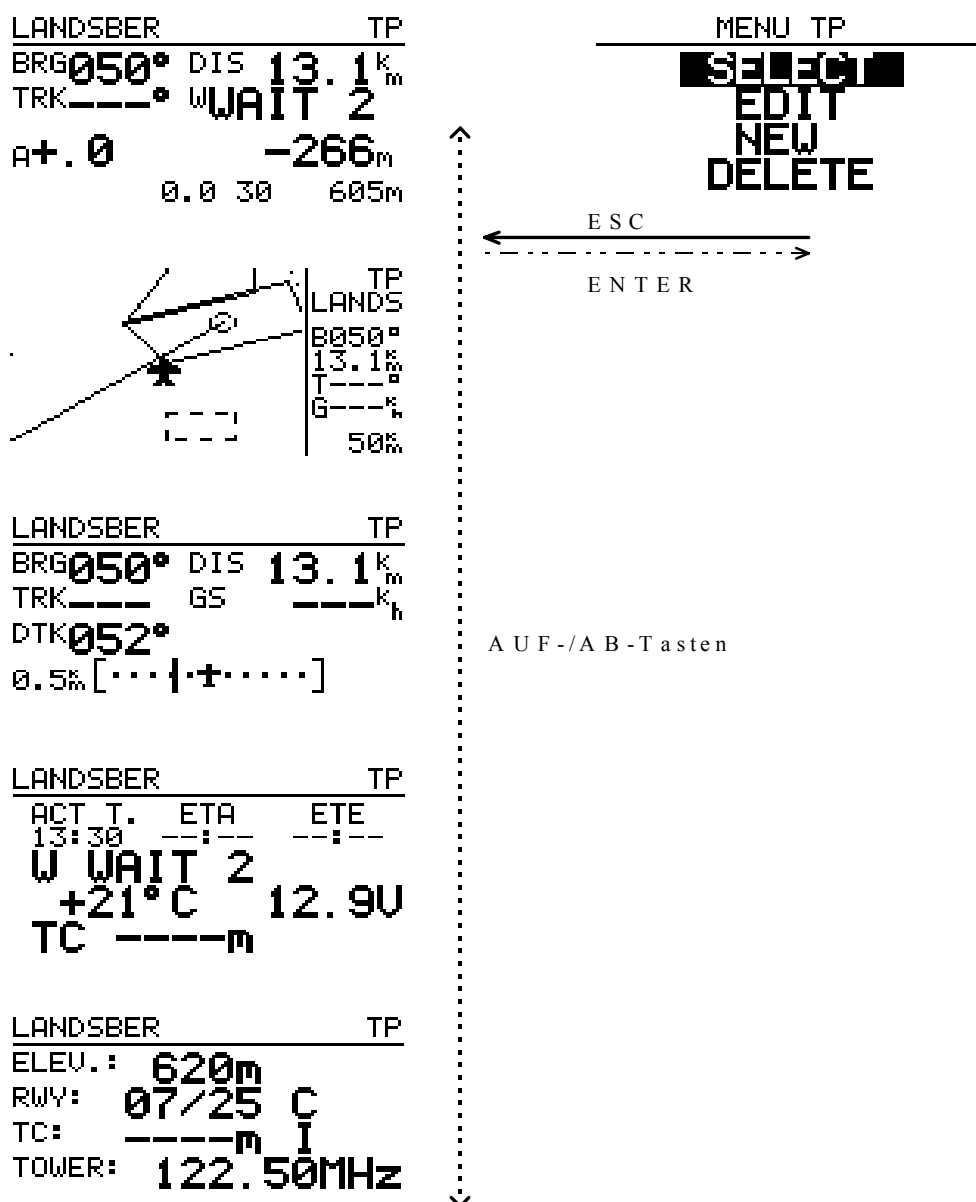

Figure 9: TP mode structure

After the selection of the TP mode with the mode selector switch the TP menu is opened by pushing ENTER. The submenus are then selected by using the arrow key. SELECT is used to select the TP; EDIT enables you to edit the stored data; NEW is used when you want to add some new TP's; with DELETE the stored TP is deleted.

To enter a new TP you have to select NEW and confirm with ENTER. Now a question appears on the display whether an APT should be copied into the turning point memory: If you answer the question "COPY APT DATA" with Y (yes) the same selection appears as in the APT menu when selecting an airport. A now selected and confirmed airport is copied into the TP memory and is then available as normal TP.

If you want to enter a new turning point the mentioned question should be answered with N (no). Now you can enter a new TP. After activating the input block by pushing ENTER button. Now the name, coordinates and elevation can be entered.

The TEAM and WIND functions can also be activated from the TP menu.

Attention:

- Only these airports which have previously been copied in the TP memory can be selected in TSK menu.
- By the coordinates input pay attention on the units selected in SETUP.

5.2.1 Quick TP

The function Quick TP offers you the possibility to store your current position as a turning point. Pushing the START button activates this function (provided: GPS reception and TP mode active).

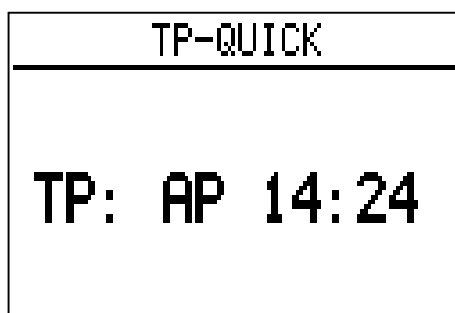

Figure 10: Quick TP

The message e.g. AP 14:24 appears on the display. This quick TP is then available under the name AP and current time it is stored by pushing the ESC button. It is possible to rename such a turning point the usual way.

5.3 Task (TSK) program

In the TASK (TSK) mode up to 100 tasks with 10 waypoint each can be stored in the DX 50. The stored tasks can be displayed graphically on the screen. All programmed turning points can be used as points for a task. If airports should be programmed into a TASK they have to be copied into the TP memory first.

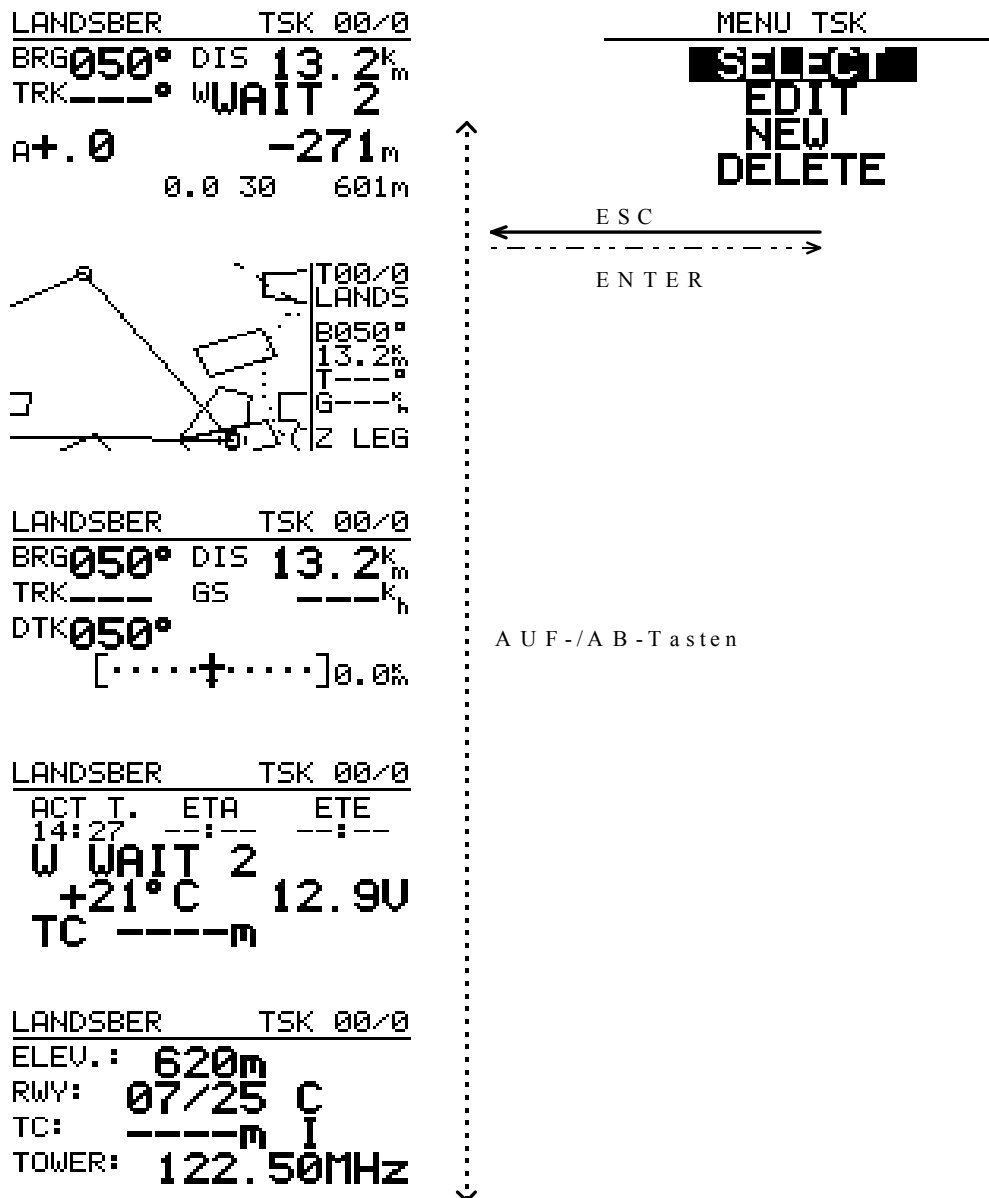

Figure 11: TSK Mode structure

There are three different possibilities to display the task graphically:

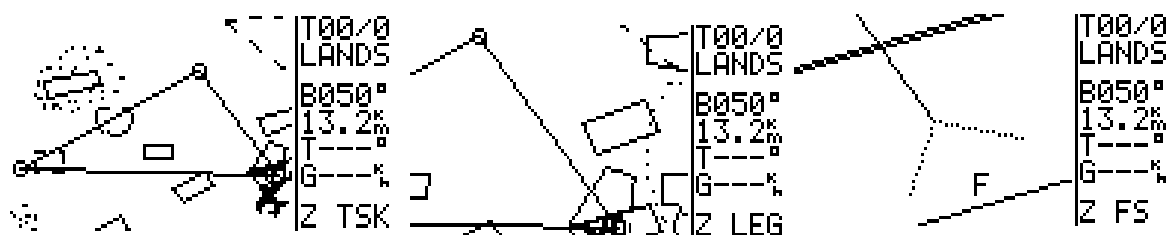

Figure 12: TSK graphic modes

By using the + or - keys the above mentioned graphic modes can be selected as long as the instrument is in the TSK mode. The scale of these three graphic modes can not be changed, as it is possible in the APT or TP mode.

The whole task, the whole active leg or the active photo sector can be shown on the display.. The active photo sector means the next sector that will be flown to. The show glider indicates the current position related to the task.

5.3.1 Selection of a TASK

After selecting the TSK mode with MODE button the TSK menu is activated by pushing ENTER. The option SELECT should be selected and confirmed with ENTER. With UP and DOWN keys you can browse through all 100 possible tasks. The number of the current task is shown on the display with the programmed waypoints below. If points are not programmed within the task the message NOT PROG appears. If you want to activate the displayed task you have to push the ENTER button. The selected task is now active.

TSK SELECT				
TSK SELECT: 00				
0	LANDSBER	5	NOT	PROG
1	ALEN-HE	6	NOT	PROG
2	KLIPPENE	7	NOT	PROG
3	LANDSBER	8	NOT	PROG
4	NOT PROG	9	NOT	PROG

On the glider navigation display the first tuning point (normally designated Number. 0) will be considered as a start point. That is normally the starting airfield but can also be a TP out of the airfield.

The information for approach to the first waypoint aren't shown until the start of the task.

5.3.2 Change of a TASK (TSK EDIT)

In TSK EDIT menu you can change already programmed tasks that means that you have the possibility to change TP's, to skip or delete one or more TP's or invert the task as well. The last waypoint before the finish can also be entered as a checkpoint.

After selecting the task in the glider NAV menu the TSK menu has to be reopened by pushing ENTER. By UP/DOWN keys the EDIT menu has to be selected and confirmed by ENTER. The DX 50 displays a question whether the task should be inverted or not. After answering Y or N the total distance of a task and the distances and courses of the single legs are displayed. The last turning point before the final point can be programmed as a checkpoint by using ENTER and UP/DOWN keys.

```

          TSK EDIT
-----
TSK 09:    40.3m  --
0 * * * *
1 VELENJE
2 ZICE TUN
3 CELJE/AD
4 NOT PROG
SELECT
INSERT
DELETE

```

If you place the cursor by arrow key to the desired turning point and activate it by pushing ENTER, the submenu in which now SELECT, INSERT or DELETE can be selected opens. By opening the SELECT menu you will be asked to enter the first four letters of the TP name. The matching turning points are displayed and are available for your selection. By using the UP/DOWN keys and ENTER the desired TP will be selected and activated.

By pushing the ESCAPE button you will be able to select between all the stored turning points in the alphabetical order.

a) Search for a name	b) Browsing through all TP's
Enter the first four letters of the TP in the usual way at the position of the four stars and confirm each time with ENTER.	Instead of entering the name push ESC button once. Now all the programmed TP's appear in alphabetical order in the line below. The selection is made by UP/DOWN keys and ENTER key.

In TP memory copied airports have to be searched by their names not by their ICAO indicator.

5.3.3 Programming of a new TASK

The programming of a new task can be made also in the TSK EDIT menu, but only with changing the previously programmed and stored task. The menu NEW prevents the overwriting of the programmed task.

As mentioned above by the TASK SELECT an empty task has to be selected and the submenu NEW should be opened. The question COPY TSK appears on the display, this is only needed to copy a task under the new TSK number e.g. to achieve a certain task order. So if you answer N (no) and confirm it with ENTER the empty task is displayed. After the answering INVERT N/Y and CP N/Y the cursor will place to the first turning point (0) which can be activated by pushing ENTER. As by editing the submenu SELECT, INSERT, and DELETE appears. Chose SELECT and you will be able to select TP's out of the TP's database and by pushing ENTER the selected TP will be displayed in the corresponding position.

a) Search for a name	b) Browsing through all TP's
Enter the first four letters of the TP in the usual way at the position of the four stars and confirm each time with ENTER.	Instead of entering the name push ESC button once. Now all the programmed TP's appear in alphabetical order in the line below. The selection is made by UP/DOWN keys and ENTER key.

The whole process is repeated as long as all desired turning points of the task are programmed. As soon as more than two points are entered in the task the DX 50 calculates the total distance of the task as well as the distances and courses of the single legs and displays them.

5.3.3.1 Declaration of a TASK (DECLARE only by DX 50 FAI)*****

The declaration of a task is a very important procedure that should be done on the ground before the flight. DECLARE is a submenu in the TSK mode. If the declaration of the task is not correct the record flights (badges) are invalid. There are two different ways how to declare a task:

- a) - with a PC by header transmission (see LXFai manual)
- b) - by DX 50 as follows:

Select a task in a usual way.

```

      TSK DECLARE
-----
DISTANCE: 226.7%
0 CELJE TAKE OFF
1 CELJE
2 LJUBLJAN 58.9% 268°
3 AJDOUSCI 57.6% 229°
4 CELJE 110% 068°

```

With copy a selected task can be copied or after N (no) edited. The DX 50 task doesn't consider the TAKE OFF point as a start point so this should be entered. After pushing ENTER button

```

      TSK DECLARE
-----
DISTANCE: 226.7%
0 CELJE
1 CELJE
2 LJUBLJAN
3 AJDOUSCI
4 CELJE

```

SELECT
INSERT
DELETE

appears a window with SELECT, INSERT and DELETE now you can edit the selected task if you want. The same holds true for LANDING.

After pushing ESC the window closes, the task is declared and a message TASK DECLARED appears. During the flight many different tasks can be selected and flown, but in FAI logger the only active task is the declared task.

If the task is already declared the following message appears after the selecting DECLARE:

TSK DECLARE

**OVERWRITE
DECLARED
TASK ? N**

If the answer is N (no) the previously in logger declared task is displayed and you can return to the TSK menu by pushing ESC. If the answer is Y (yes) the current selected task is displayed that means the last declared task has been altered.

IMPORTANT!

After every landing the task must be declared again although the task stays the same.

The LXFAI program enables you to declare task on your PC. The task should be correctly defined in FLIGHT INFO menu and then transmitted to the DX 50. It is then automatically declared and the TSK DECLARE is not necessary.

5.3.4 Deletion of a TASK (DELETE)

You can delete a task that has been selected as active before. To delete the whole task select DELETE menu. BY choosing Y (yes) the deletion process is confirmed, by choosing N (no) the deletion process is terminated.

5.3.5 Flying with a TASK

When using the TSK mode note the following remarks:

- The corresponding task must have been programmed and activated.
- It is recommended to perform a task check before the flight. This can be done by using the TSK subprogram TSK EDIT. In this program all leg distances, all leg courses and the total distance of the task are calculated and displayed. Possible coordinate or programming errors of the turning points can now be recognized and corrected in time.
- A programmed task always has to be started manually when passing the start point by holding the START button at least for a second.
- However the instrument switches automatically to the next leg of the task when passing the waypoint sector.
- When flying in the TSK mode it can be quit any time to continue the flight in another mode (e.g. TP, APT, or Near Airport). However shortly before reaching the way of final point you have to return to the TSK mode because otherwise the statistic documentation is incomplete.

As long as the task is not started the DX 50 displays all flight data (course, distance etc.) related to the first entered point of the task.

5.3.6 Starting of a TASK

The photosector dimensions as also the size of a radius (Start, TP or Finish radius) and thus the dimension of the corresponding sectors can be selected in the SETUP TSK menu.

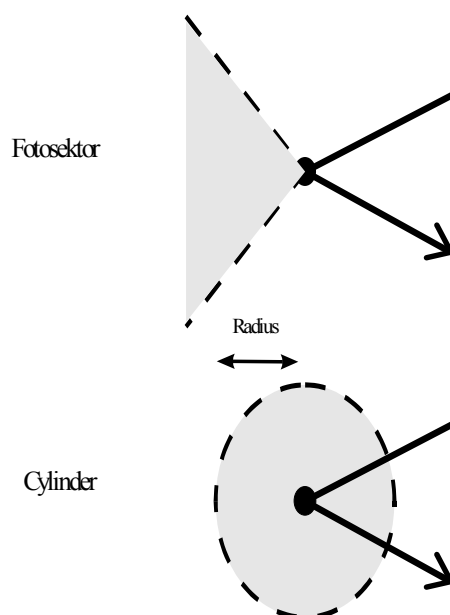

Figure 13: Rounding modes

To start a task or to change to the next leg of a task when rounding a waypoint the START button has to be pushed in the following manner:

Photosector/Cylinder	
inside	outside

starting a TSK	hold START button for 1 second	hold START button for 5 seconds
rounding a way point	automatic	hold START button for 5 seconds

After completing the task a TASK END message appears which is displayed until the glider stops (the total pressure is relevant factor for determining whether the glider is moving or not and not the calculated ground speed of the GPS receiver).

To delete the TASK END message (only during the flight) the task has to be restarted by selecting RESTART. Note that the statistic of the already flown task will be influenced when activating the first leg again.

5.3.7 Restart of a TASK (TSK Restart)

It could be necessary to restart an already activated task (for example a second start in a glider competition). By activating RESTART the statistic of the last flown task is deleted.



Figure 14: TSK RESTART MENU

The TSK RESTART display shown in figure 14 is activated by pushing ENTER button. Therefore the instrument has to be in the TSK mode. Now select the menu RESTART with the up and down switch and push the ENTER button. The following display will appear:

```

TSK RESTART
-----
TSK IS STARTED:
RESTART: N

```

Figure 15: TSK RESTART confirmation

If you answer the question RESTART with Y (yes) your task will be reset, that means that first entered point of the task will appear as navigation point on the TSK navigation display. Now the task has to be restarted e.g. by second start when passing the start line or photosector by pushing ENTER button.

IMPORTANT: RESTART has no influence on the declared task in the FAI Logger.

5.3.8 Setup program

In the setup program all parameters that are necessary for the later use of the DX 50 can be programmed.

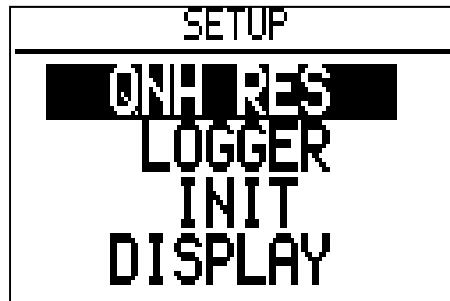

Figure 16: SETUP mode

The above figure shows the display that appears after selecting the SETUP menu. The following diagram shows the particular submenus of the SETUP mode and their meaning or their activation respectively:

QNH RES	ENTER → ← ESC	Input of: QNH (for altitude correction during the flight) ALT. R = reserve altitude for the final glide BUGS = the polar deterioration because of midges (BUGS) in % entered in 2,5% steps to max. 30%
LOGGER	ENTER → ← ESC	Input of the FAI Logger parameters (only by DX50 FAI)
INIT	ENTER → ← ESC	Input of: Vario Filter Vario integration time (10, 20 or 30 sec.) Vario range selection (2.5, 5 or 10 m/s) Speed command audio dead area (0 to +-2 m/s) Autom. Vario-/Speed command turn on: OFF / GPS or TAS
DISPLAY	ENTER → ← ESC	LCD contrast (0 to 100%)
PC	ENTER → ← ESC	PC communication
PASSWORD	ENTER → ← ESC	Input of the Password (96990), then skipping into the SETUP PASSWORD submenu

Figure 17: Structure of the SETUP menu

The following diagram shows the structure of the Setup Password menu. All the named functions can be altered only if the **password (96990)** is entered:

TSK	ENTER → ← ESC	TSK-Mode: selection of the photo sector, radius Start-Cylinder 0.1- 9.9 km
-----	------------------	---

		TP Cylinder 0.1- 9.9 km adjustable Finish Cylinder 0.1- 9.9 km
GPS	ENTER → ← ESC	Selection of the geodetic system. Normally: WGS 1984 Input of the UTC offset related to the identical local time
UNITS	ENTER → ← ESC	Selection of the desired units: Coordination format Distance: km, nm, ml Speed: km/h, mph, kts Vert. Speed: m/s, kts Wind: km/h, kts, mph, m/s Altitude: m, ft Load: kg/m ² , lb/ft ² , OVERLOAD
SYMBOL	ENTER → ← ESC	Glider symbol in graphic display BIG/SMALL
AIRSPACE		Selection of the airspace for the graphic display
NMEA	ENTER → ← ESC	Activation or inactivation of the following NMEA messages: GPGGA, GPRMC, GPRMB, GPGLL, GPR00, GPWPL, GPLX1
PC	ENTER → ← ESC	PC communication: Selection of the communicating speed normally: 19200 bps
DEL TP / TSK	ENTER → ← ESC	Deletion of all in DX50 stored TP and programmed TSKS. Confirmed with Y (yes) or N (no)
POLAR	ENTER → ← ESC	Input of the glider polar and the glider type (USER1 or 2), activation of the stored polars
TE. COMP.	ENTER → ← ESC	Input of the electronic compensation rate and the electronic compensation filter from 1% to 150%. Attention: by TE probe compensation the TE= 0% must be entered!
AUDIO	ENTER → ← ESC	Adjustment of the tone for Vario or Speed command in negative and positive range: frequency, audio type, dead area and Audio Demo
INPUT	ENTER → ← ESC	Inverting the ext. speed command switch Ext. temperature probe ON or OFF Temperature correction for the ext. temperature probe
INDICATOR		Function selection for the LCD vario indicator

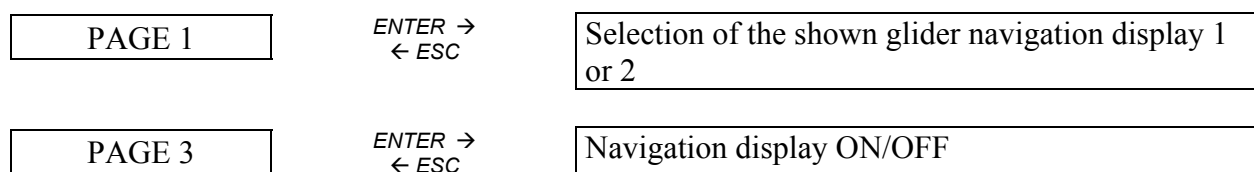

Figure 18: Structure of the SETUP PASSWORD menu

5.3.8 QNH RES

Here the new **QNH** can be entered (when switching ON the DX 50 the actual QNH was entered) this is needed if during a long flight the QNH changes. After the input of the new QNH value the electronic altimeter automatically considers the new value in calculations so the correct altitude is displayed.

The input of the reserve altitude is needed to reach the selected airfield on a safe altitude. This altitude is added to the absolute airfield elevation.

5.3.9 LOGGER (only by DX50 FAI)

All the adjustments influence only the FAI Logger and have no influence on the flight.

The main menu has 4 submenus:

```

FLIGHT SETUP
-----
FLIGHT INFO
LOGTIME
(I) RECORD
(J) RECORD

```

FLIGHT INFO	Pilot and glider data
LOGTIME	Logging time interval selection
(I) RECORD	Adjustment of the extra parameters which are shown (not necessary)
(J) RECORD	Adjustment of the extra parameters which are shown (not necessary)

The shortenings for the (I) and (J) RECORD:

GSP	ground speed	
IAS	indicated air speed	
TAS	true air speed	
TRM	magnetic track	
HDT	true heading	
HDM	magnetic heading	
TRT	true track	
TEN	total energy	
WDI	wind direction	
WVE	wind velocity	

5.3.10 INIT

In the INIT menu you can enter the following parameters:

VARIO FILT.	Vario filter
VARIO INT.	The selection of the integration time of the interval integrator (normal value: 20 Sec.)
VARIO RNG.	Vario range adjustment (2.5, 5 and 10 m/s)
TAB	Audio dead area by SC (range from 0 to ± 2 m/s)
AUTO SC	Activation of the automatic vario/speed command switch
GPS	When circling switches the GPS from speed command to vario.
OFF	The switching on is achieved by an external switch (on stick or flaps)
100 km/h	The switching on depends on the speed (adjustable from 100- 160 km/h)

5.3.11 DISPLAY (graphic display)

Here you can select the display contrast (from 0 to 100%), the view angle and the light relation.

5.3.12 PC

In this menu you can transfer data from PC or notebook to the DX 50 or read it from DX 50. Therefor the LXFAI program should be installed and the right connect cable should be applied (see LXFAI manual).

On the PC the menu TRANSFER has to be opened and the menu PC in the DX 50. With ENTER the timeout from 0 to 9 seconds is counted. If in this time the connection is established the following note appears on the display:

CONNECT

The data transfer is now possible. All the operations are made on the PC. After the transmission has ended the ESC button on the PC has to be pushed to break the connection. The timeout appears again. The SETUP PC menu is automatically closed.

If the connection isn't possible the time will run out and the PC menu will be closed. For all other information about the data transfer see description of the LXFAI program.

5.3.13 PASSWORD

The menu PASSWORD enables you to adjust some other data that are placed in different submenus (glider and pilot data).

This data are secured with PASSWORD:

This password can not be changed:

96990

After the entry of this combination (the tel. Number of FILSER ELECTRONIC) the submenus are displayed:

5.3.14 TSK

The selection of the mode of the task start and the radius around the waypoint inside of which the next leg of the task is started.

There are two different modes:

- Cylinder
- photosector

The cylinder radius can be selected (from 0.1 to 9.9 km).

5.3.15 GPS

The GPS receiver operates always with UTC (before GMT). In this submenu for the time display a time offset can be entered. Example:

- UTC+0: the UTC is shown
- UTC+1: the c.e.t. during winter is shown (MEZ= UTC +1)
- UTC+2: the c.e.t. during summer is shown (MESZ= UTC +2) etc.

The GPS DATUM is normally shown in WGS 1984. This option enables to adapt the coordination system of the GPS to the Earth. This should not be changed in order to get the right position data.

5.3.16 UNITS

In the submenu UNITS the different forms and units for the fly data presentation can be selected:

- Coordinates of the TP's in decimal minutes or seconds
- DISTANCE: km, nm, ml
- SPEED: km/h, kts, mph
- Climbing/descending (VER.SPEED): m/s, kts
- WIND: km/h, kts, mph, m/s
- ALTITUDE: m, ft
- WINGLOAD kg/m², lb/ft², OVERLOAD

5.3.17 SYMBOL

In this submenu the glider symbol size can be altered.

5.3.18 AIRSPACE

In the AIRSPACE submenu the airspace info which are shown on the graphic display can be selected:

- AIRSPACE: DISABLE/ ENABLE
- CTR Zones
- R, P, D Zones
- TMA Zones
- TRA- Zones
- TIZ- Zones

All the declared airspace data can be displayed separately or together. The function AIRSPACE can be completely disabled.

5.3.19 NMEA

In the NMEA menu the NMEA0183 data string can be configured. This string is needed for the connection of special devices such as HandyMap. The NMEA data strings can be enabled or disabled. Which data strings are needed for the corresponding external device depends on the manufacturer. If on the NMEA interface no ext. devices are connected then all the NMEA data strings can be disabled.

5.3.20 PC (Adjustments)

In the submenu PC the communication baudrate is selected. The default value is 19200. The communication is possible only when the two devices don't differ in the baudrate value.

DEL TP/TSK

Within this submenu you are able to delete all the programmed TP's or TASKS. This happens if the question "DELETE ALL TP AND TSK:" is answered with Y (yes). The airport database stored in the DX 50 won't be altered.

POLAR

In the POLAR menu the speed polars of some 30 gliders are stored, which can be easily selected and activated.

It is also possible to enter the two user defined polars.

Under the "min. load" the wing load on which the polar is based should be entered.

5.3.21 TE COMP.

In this submenu the type of electronic compensation and its value can be selected. The default value is set at 0 %.

Please pay attention:

- By the TE probe compensation the compensation value of **000%** should be entered.
- If **electronic** compensation is wanted the desired values can be entered in TE COMP.

The preset of the TE values for the specific glider type is not possible, because the optimal electronic compensation depends on many different factors. The exact setup can be made only empirically during the test flight in calm air.

The following flight conditions are necessary for the optimal compensation:

- Absolutely calm air
- The DX 50 should be in the Vario mode (no SC automatic)
- Start the SETUP program and open the menu TE COMP.
- Accelerate to approximately 160 km/h and hold the speed constant for some 20 seconds.
- Then slowly pull up to reach 80 km/h. by the optimal TE compensation the variometer should display the polar descending. ?????

If the vario shows higher descending then the variometer is over compensated (the TE value should be lowered).

If the vario by pull up a higher climbing (by under compensation) the TE value should be higher.

This procedure should be repeated till the optimal compensation is achieved.

The valid values range from 1 to 150 %.

The filter values can range from 0 to 9.

5.3.22 AUDIO

This submenu enables you to setup the audio signals for variometer and speed command. You are able to select the frequency, the type of the audio signals and also the dead area.

These selections are possible:

SC	The dead area by SC mode: SC Audio signal by positive and negative SC SC POS Audio signal only by positive SC SC NEG Audio signal only by negative SC
VARIO	Type of the audio signal in VARIO mode: LINEAR normal audio signal in whole range LIN/NEG normal audio signal interrupted by descending LIN/POS normal audio signal interrupted by climbing DIGITAL digital audio signal in whole range DIG/NEG digital audio signal interrupted by descending DIG/POS digital audio signal interrupted by climbing
0%	The input of the frequency in Hz by 0% deflection on the analog instrument
+100%	The input of the frequency in Hz by full positive deflection
-100%	The input of the frequency in Hz by full negative deflection

The **AUDIO DEMO** menu enables you to listen to the demonstration of the audio signals selected.

5.3.23 INPUT

In the INPUT menu some analog functions can be selected:

SC INPUT	The external SC switch setup: ON: if the switch is OFF → Speed command mode if it is ON → Vario mode OFF: if the switch is OFF → Vario mode if it is ON → Speed command mode
TEMPERATURE	With this option you can disable the temperature displaying (if there is no ext. temperature probe)
TEMP. OFF.	The external temperature probe can be compensated (for +/- 9°).

5.3.24 INDICATOR

In the Indicator menu the pilot is able to configure the vario indicator as desired.

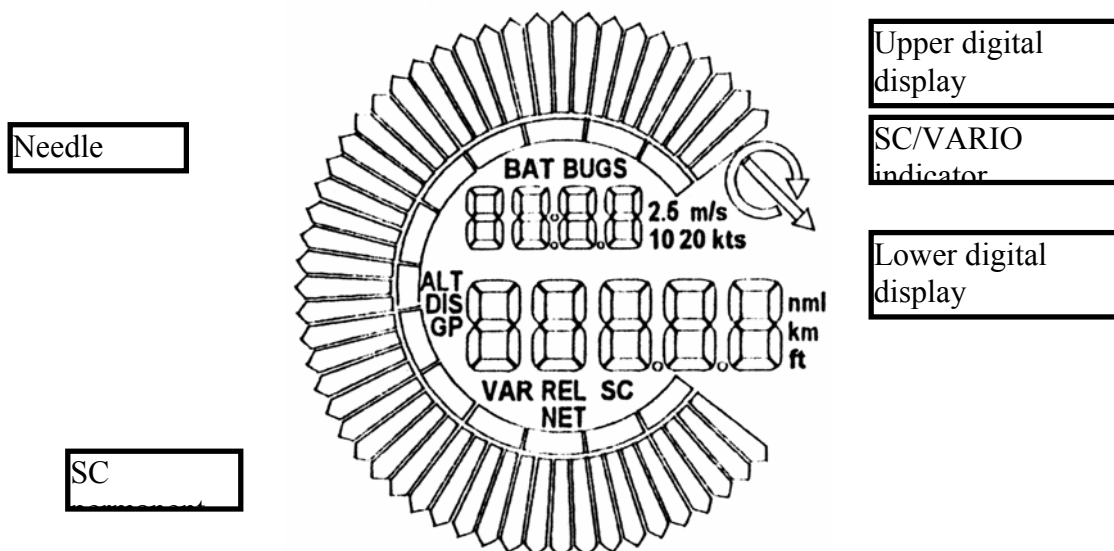

The configuration is separated for the two flight phases: VARIO (circling) and Speed command (SC).

dist	Distance to the TP or APT
speed	TAS indication
legsp	Average speed in the current leg
alt	Altitude
gldpt	Glide deviation
flt.t	Flying time
leg.t	Leg time
aver	Integrator
time	Current time
rel	Relative Vario
netto	Netto Vario
SC	Speed command

```

SETUP INDICATOR
-----
Contrast:  HI
Mode      VAR  SC
Needle:  vario sc
Lwr.nr:  speed alt.
Upr.nr:  flt.t leg t

```

From all the possible combinations the most convenient can be selected.

5.4 Near Airport program

The program NEAR AIRPORT continuously calculates the 10 nearest airports to your current position. These are indicated on the display with the following data (see figure 19).

- the abbreviated name of the airport (max. 6 signs)
- the bearing to the airport
- the distance to the airport

The number of the calculated airport (max. 10)

```

1/10 NEAR AIRPORT
-----
BRG 00000000 282° 12m
LANDSBERG/LE 050° 13m
KAUFBEUREN 218° 19m
ALTENSTADT 157° 19m
SCHWABMUENCH 346° 21m
MINDELHEIM-M 305° 22m

```

Name of the
nearest airport

BRG to the
airport

Distance to the airport

Figure 19: Near Airport

By UP/ DOWN keys the desired airport can be selected. If it should be activated, that means if you want to fly to this airport, the ENTER button has to be pushed. The program automatically returns to the APT mode where now the selected airport is active and is available for navigation.

Attention:

Please note that before using the Near Airport function the instrument only offers exact data after a good GPS receipt of at least 5 minutes (otherwise the message “GPS BAD” is displayed).

Any way only these airports are displayed which have been stored in the APT memory of the DX 50!

5.5 Statistic program

The DX 50 has a very comprehensive statistic with the logbook. There are two different modes:

- Statistic during the flight
- Statistic after the flight with graphical presentation of the barograph, flying route, photo sectors and PC interpretation

Statistic during the flight

The flight data can be read from the STATISTIC menu during the flight:

```

22073 3
-----
FLIGHT:
12:30:05 - --:--:--
Duration: 0:12:47
Speed: 159k
Vario: 0.1% 0% 0
Engine: 12°47"

```

The following parameters are displayed:

- Start time
- Duration
- Variometer (digital averager and portion of circling)

After pushing the AB button the leg statistic is displayed

```

26873 3
TSK 00/1:
Time: --:--:--
Duration: 0:10:58
Speed: 100%
 vario: 0.1% 15% 0
Engine: 10*57"

```

TSK 00/1 means that the 1. leg statistic of task 00 is displayed.

Time The arrival time (time when the TP was reached). If the time isn't displayed the TP hasn't been reached yet (means that the current leg statistic is displayed).

Duration The duration of the leg.

Statistic after the flight

This statistic is official for the FAI regulations and is available some 5 minutes after the landing.

IMPORTANT!

The FAI regulations require a straight line by barograph flight and ending. ? Therefore it is recommended to switch ON the DX 50 5 minutes before the start and not to switch it OFF for 5 minutes after the landing. All the procedures are surely finished when this message (only by DX 50 FAI) appears:

CALCULATING SECURITY

After appearance of this message the statistic is available. If this procedure is not respected and the DX 50 is switched OFF immediately, this procedure will be repeated after switching it ON again and the data will be stored.

In the DX 50 Statistic menu the LOGBOOK will be presented.

```

LOGBOOK
-----
25.12.97 12:30 13:07
24.12.97 8:58 9:03

```

By using the UP/DOWN
desired flight. After

PLEASE WAIT is displayed and after pushing ENTER the following data are displayed:

keys you are able to select the
pushing ENTER the message

```

Flight: 1 31.12.97
-----
PILOT: John_Smith
GLIDER: DG-303
DURATION: 11:19:03 -
TASK: 40.3

```

ROUTE
HEIGHT
STAT

After selecting the ROUTE option the flight route is displayed (it may take few seconds)

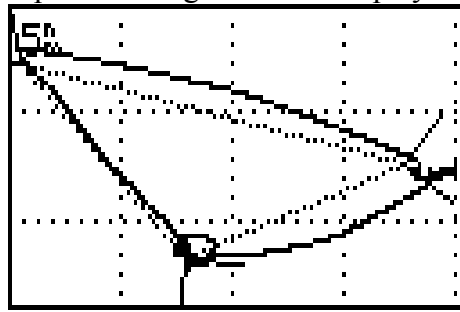

The same holds true also for the barograph (ROUTE menu is closed by ESC activated)

for the barograph (ROUTE and HEIGHT should be

After the flight statistic is activated the DX 50 calculates the TASK (this may last few seconds).

If no task is flown then also the task statistic is not available and the following message appears:

```

Flight: 1 25.12.97
-----
PILOT: John_Smith
GLIDER: DG-303

DURATION: 0:34:46
16:22:23 - 16:57:09

TASK: NOT SPECIFIED
    
```

TSK : NOT SPECIFIED
 been declared (DECLARE TASK) in TSK menu.

means that the task hasn't

It the task has been flown but not declared the statistic is surely available but such flights are by FAI regulations not valid and should be announced before the start.

IMPORTANT!

All the flights that require announcement must be declared. If the pilot forgets to start the task in the DX 50 that won't influence on the FAI scoring if the task has been declared.

After finishing the task the following data are available (this might take few seconds):

<pre> LOGBOOK ----- 31.12.97 11:19:03 - 12:10:25 </pre>	<pre> Flight: 1 31.12.97 ----- PILOT: John_Smith GLIDER: DG-303 DURATION: 0:51:22 11:19:03 - 12:10:25 TASK: PLEASE WAIT ENT ENT STATISTICS: AB button CELJE/AD - VELENJE 11:21:31 - 11:33:46 Duration: 0:12:15 Distance: 11.7% Speed: 57.34% </pre>	<pre> Flight: 1 31.12.97 ----- PILOT: John_Smith GLIDER: DG-303 DURATION: 0:12:15 11:19:03 - 12:10:25 TASK: 40.3 STATISTICS: LEG 1/3 CELJE/AD - VELENJE 2671% - 5046% Vario: 2.0% 1% Track dist.: 12.0% XC speed: 112.99% </pre>
---	---	---

AB button

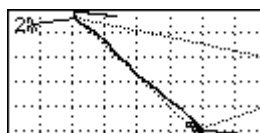

```

Flight: 1 25.12.97
-----
PILOT: John_Smith
GLIDER: DG-303

DURATION: 12:30:05 -
TASK: 79.8
    
```

AB button

ROUTE
 HEIGHT
 STAT

AB button

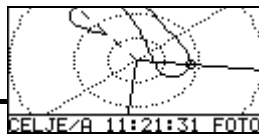

The next legs can be selected by +/- keys. When the desired leg stat. is displayed the UP/DOWN keys are used to operate.

XC speed - if two TP's of the leg were not reached at the same altitude, the average speed is not realistic (especially by the final glide). **XC speed** is the value which shows how much you have lost or gained because of that. **XC speed** can be positive or negative.

To zoom the photo sector push ENTER button. The same holds true for the zooming in leg mapping. After pushing ENTER the cross appears in the lower left corner of the display. The +/- keys are used to change its position and after selecting the segment to be zoomed push ENTER to confirm the selection.

5.6 POS program

The program position informs you about:

- number of the GPS satellites that are momentarily tracked
- GPS receiver status (2D- or 3D navigation or LAST FIX)
- the current position (indication of coordinates)
- the altitude (barometric measured by DX 50)
- the time (UTC or configured time in the INIT menu)
- Stop watch (as soon as it was started by pushing the START button)

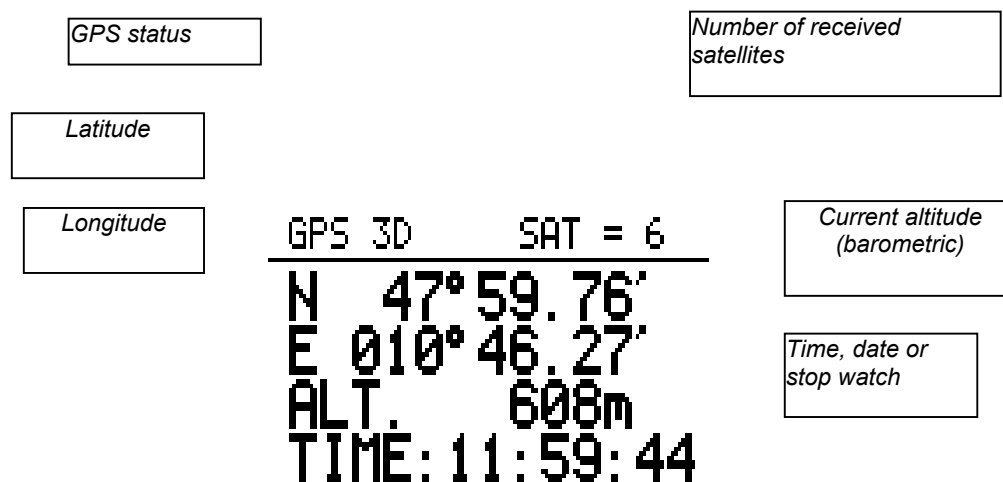

Figure 20: Positions display

To display the date instead of the time the ENTER button has to be pushed. The current date will appear as long the button is pushed.

The stopwatch can be activated by pushing the START button:

- START stop watch selection
- pushing START again stop watch will start
- pushing START again stop watch will stop
- pushing START again the stop watch will reset

By pushing ENTER button the current time is displayed again.

Attention:

The indication “Last Fix” appears as long as the GPS is not ready for navigation. Meanwhile those coordinates are indicated which the GPS module has stored last. The current position coordinates are only indicated as long as the GPS is in the 2D or 3D mode.

6 Appendix

6.1 Cable connection

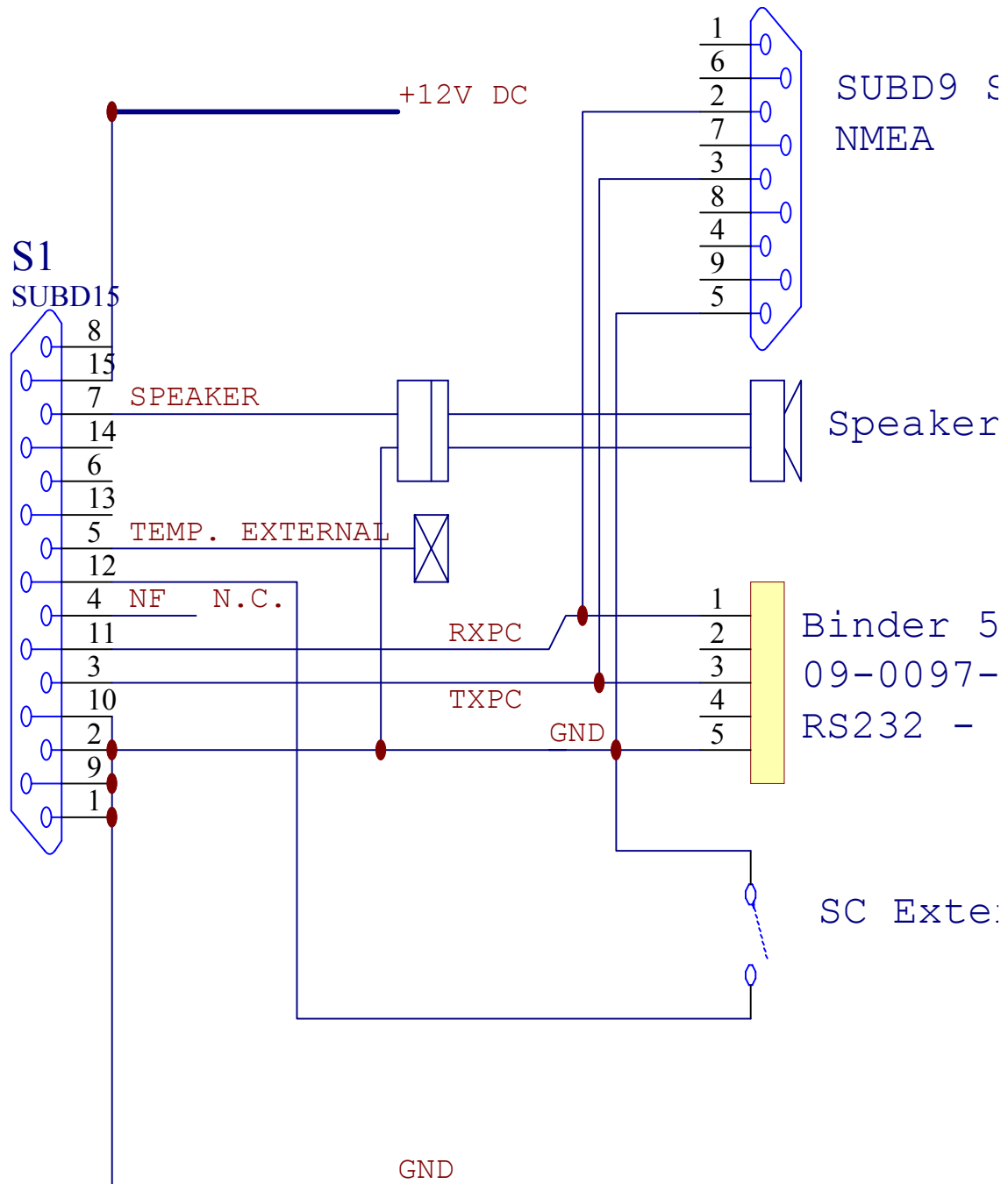

6.2 Drilling plan

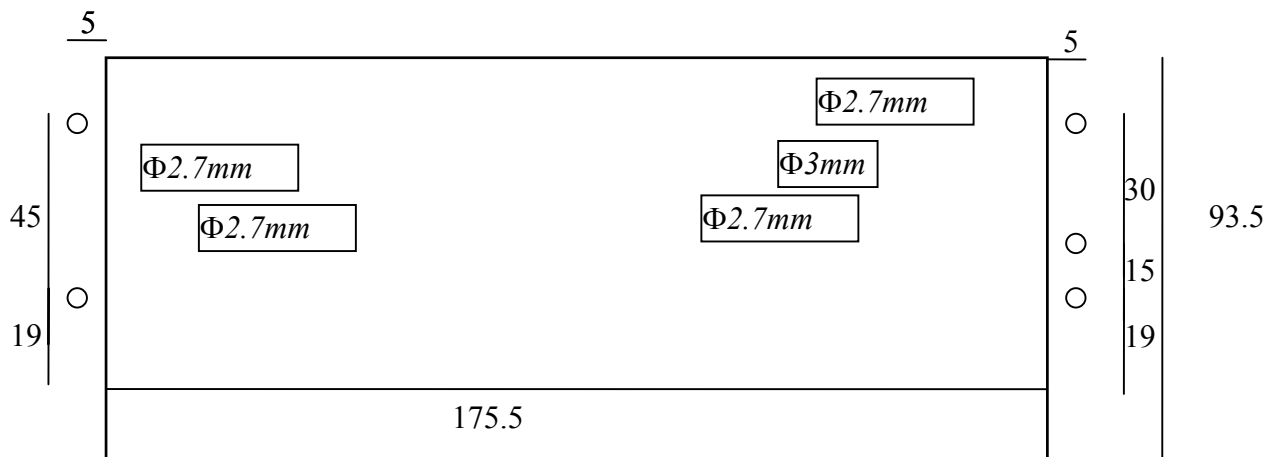

6.3 Short notes

The keyboard:

Mode selection: “ Mode ” button plus “ + ” or “ - ” buttons

Selection of menus in current mode: UP/DOWN keys

ESC: to finish editing or to skip the whole line; to switch OFF the DX 50 (Timer)

ENTER: to start editing or to confirm the entered value

START: to start the task, one character back by editing, to start the stopwatch

MC: after pushing “ MC ” and “ + ” or “ - ” the MC is altered

“ + ” and “ - ” : to zoom in Task menu

EVENT: Start of the faster logging

Volume adjustment: the speaker key and “ + ” or “ - ” key

FAI Logger:

TASK DECLARE: declares the task in the FAI Logger. Do not forget by record flights or glider competitions.

PASSWORD